



» DATA SECURITY & EFFICIENCY

Operational reliability for data centers



*Die like Wai is die bääste**

* Saterland Frisian for “The straight path is the best”



Our company is synonymous with innovation and development. These have been the key aspects of our work since our company was established. We have always focused on continuous communication and added value in every case in order to make the best-possible decisions from an economic, ecological and social point of view.

Only if all these aspects are taken into consideration we can ensure sustainability – and the name HANSA stands for sustainability today.

Jan Neumann
Managing Director



ABOUT US

Since 1961, HANSA Klimasysteme GmbH has had its headquarters in Strücklingen in the municipality of Saterland – which, with its Saterland Frisian dialect, is recognised as the smallest language enclave in Germany. However, we speak plainly through our products.

Our company

Since the company was established, we have earned a positive reputation throughout Germany and far beyond for the construction of air handling equipment for schools, sports halls, swimming pools, hospitals and industrial and process engineering applications. On this basis, we offer a broad range of different air conditioning units for a wide variety of applications.

We guarantee a maximum level of quality, functionality and reliability, as well as excellent energy efficiency. Throughout the

We have been the guarantee for high-quality, technically sophisticated air conditioning systems for many decades. Our company is distinguished by continuity and stability, with the Neumann family having managed the enterprise since 1971.

course of our development work, numerous property rights have been registered with the European Patent Office, where they were found to be patentable and worthy of protection.

As a member of RLT Herstellerverband e.V., the AHU manufacturers' association, we design our units to comply with AHU directives, ensuring that our customers and the operators of our systems enjoy quality, operational reliability and legal certainty at all times.

Our team

We continuously train our employees and young talent in order to safeguard our future. The HANSA team consists of experienced skilled professionals in the areas of air handling equipment manufacturing and the associated specialised divisions for refrigeration technology and control technology and systems.

Design and production are executed under QM conditions and in accordance with DIN EN ISO 9001:2015.

Our sales team consists of experts who are certain to plan and develop the ideal solution for you.

Our philosophy

Our goal is to fulfil our customer's wishes in an optimum manner and, also, contribute to the protection of the environment. We provide systems for this purpose which, thanks to flexible production processes and modern components, can be adapted to the individual operating conditions at customers while simultaneously consuming as little energy as

possible. Investment and energy costs also fall, as the energy needs of the entire system and individual modules can be reduced without impairing the performance of the system.

We have been a climate-neutral company since 2020, and the manufacture of our products is also climate-neutral.

Committed to the climate – and not only through our equipment



HANSA is a member of the Herstellerverband Raumlufotechnische Geräte e.V. association for AHU manufacturers

DATA SECURITY

Maximum operational reliability for your data center

Achieving consistent temperatures in the area of components to be cooled and the efficient removal of major heat volumes are the main tasks performed by our air handling units.

Reliability and redundant heat dissipating units in particularly sensitive application cases ensure that you enjoy maximum operational reliability.

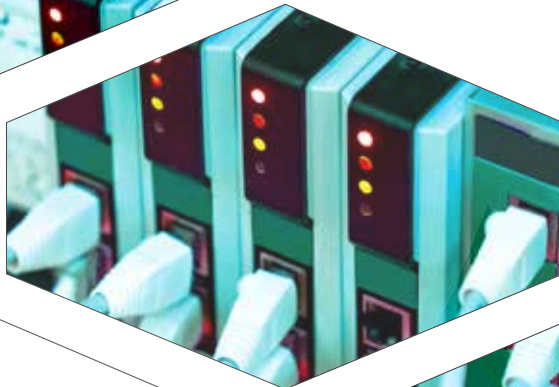



Your benefits

- Economical and cost-efficient
- An optimised carbon footprint
- 3D planning
- Remote monitoring
- Highly customisable

IT cooling

HANSA heat dissipating units are highly customisable air handling and complete air conditioning units embodying maximum energetic efficiency. They can be adapted to suit practically all spatial con-

ditions and are employed wherever high thermal loads need to be dissipated. You can also benefit from our lead in compactness, reliability and efficiency.



High-efficiency cooling

Climatic conditions to be taken into consideration vary considerably, depending on the customer and application involved. HANSA can provide you with customised solutions in this respect. When compared to split air conditioning devices, for example, our patented 4-flap

technology for the Deutsche Telekom climate model achieved energy savings of 80%. Our lead in compactness, reliability and efficiency is impressively demonstrated through the more than 8,000 devices sold to Deutsche Telekom.





Value proposition

- ✔ Reduction of operating costs
- ✔ Maximum operational reliability
- ✔ High-efficiency cooling
- ✔ CO₂ reduction
- ✔ Sustainable through green IT
- ✔ Tailored solutions
- ✔ Precision 3D planning
- ✔ Consistent temperature
- ✔ High energetic efficiency
- ✔ Reliable data security
- ✔ Reduced failure risk

EFFICIENCY

Profitability

HANSA air conditioning units help you achieve a high level of energetic efficiency, resulting in lower energy consumption and an optimised carbon footprint

for your data centre. Innovations from our *etaTech* line further improve the efficiency of your installation.

Reduction of operating costs

Circulating units (also known as split units) only cool the air in a room subjected to thermal stress and, consequently, rely on the continuous and operationally costly use of a mechanical cooling system. On the other hand, HANSA units with free cooling exploit freely available cooler outside air, thereby reducing the running time of the mechanical refrigeration system.

Outside air temperatures in Central Europe rarely exceed the temperatures

aimed for in rooms under high thermal stress (e.g. server rooms). Our air conditioning units with free cooling use this outside air to reduce the operating times of mechanical refrigeration systems in Germany to approximately 7% of the service life (data pursuant to DIN 4710, Frankfurt/Main) and, therefore, considerably lower operating costs when compared to split units. Added to this is performance control of the supply and exhaust air fans relative to the thermal load and outside air temperature.

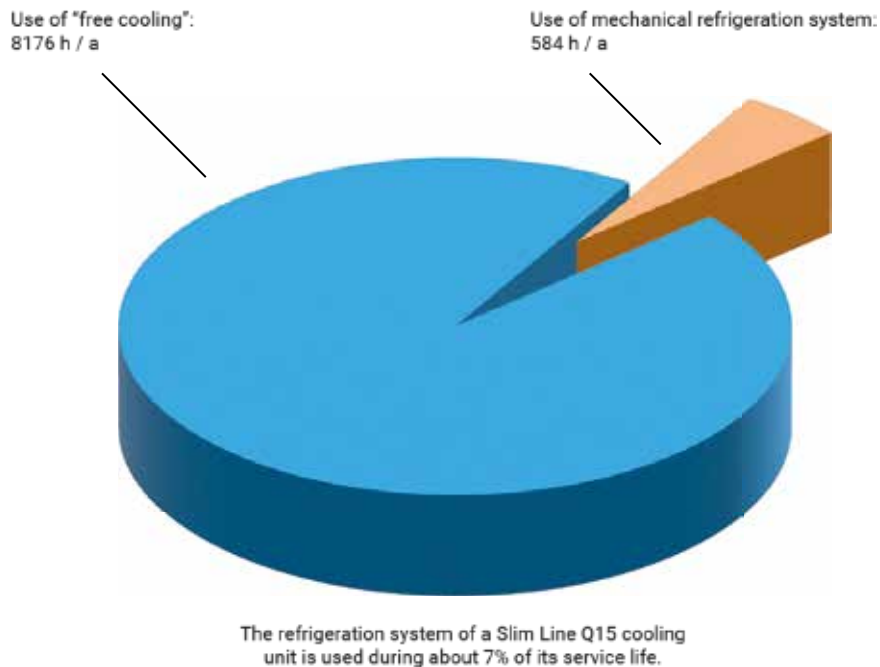

Calculation example

You have a technical premises with a cooling requirement of 15 kW. Our Slim Line Q15 would be suitable here as a heat dissipating unit.

The following electric power requirement results each year over the entire temperature range (see below for calculation details):

- Recirculating air cooling unit / Split unit: 40,550 kWh
- Slim Line: 9,671 kWh

This is equivalent to a saving of approx. 76%.

The following operating costs are calculated at an electricity price of €0.30 / kWh:

- Recirculating air cooling unit: €12,165 per annum
- Slim Line: €2,901 per annum

Savings: €9,264 per annum

Savings with free cooling

The histogram illustrates the distribution of hours in a year for the outside air temperature (location: Frankfurt / Main). On the one hand, it indicates the temperature range in which the mechanical refrigeration system of a Slim Line Q15 is active (orange) because free cooling is inadequate. The total temperature-related power requirement of the compressor and controlled fans for the Slim Line Q15 (green) and a 15 kW recirculating

air cooling unit with external condenser (yellow) is also illustrated.

The reduction in the power requirement of the Slim Line unit following deactivation of the refrigeration compressor for outside air temperatures below 22°C is clearly identifiable, while the recirculating air cooling unit consumes a practically constant level of power for the refrigerator and circulating fan.

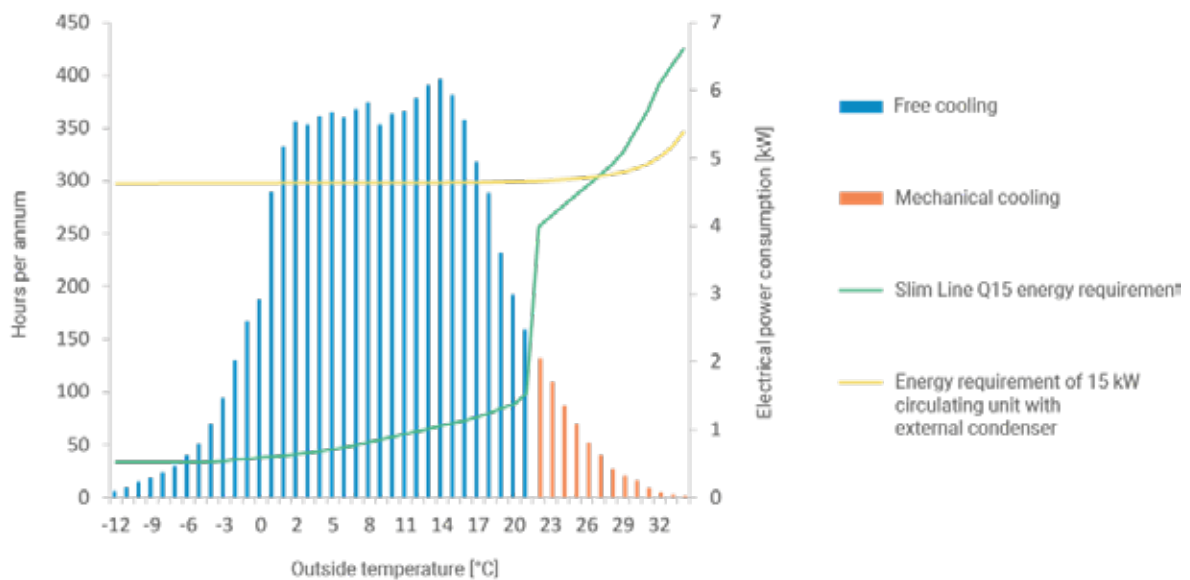



Reducing energy consumption

The total energy requirement resulting from use of the mechanical and free cooling and operation of the drive of both fans is indicated in the image for

the relevant temperature range (green). The requirement of a recirculating air cooling unit with an identical refrigeration system (yellow) is also indicated.

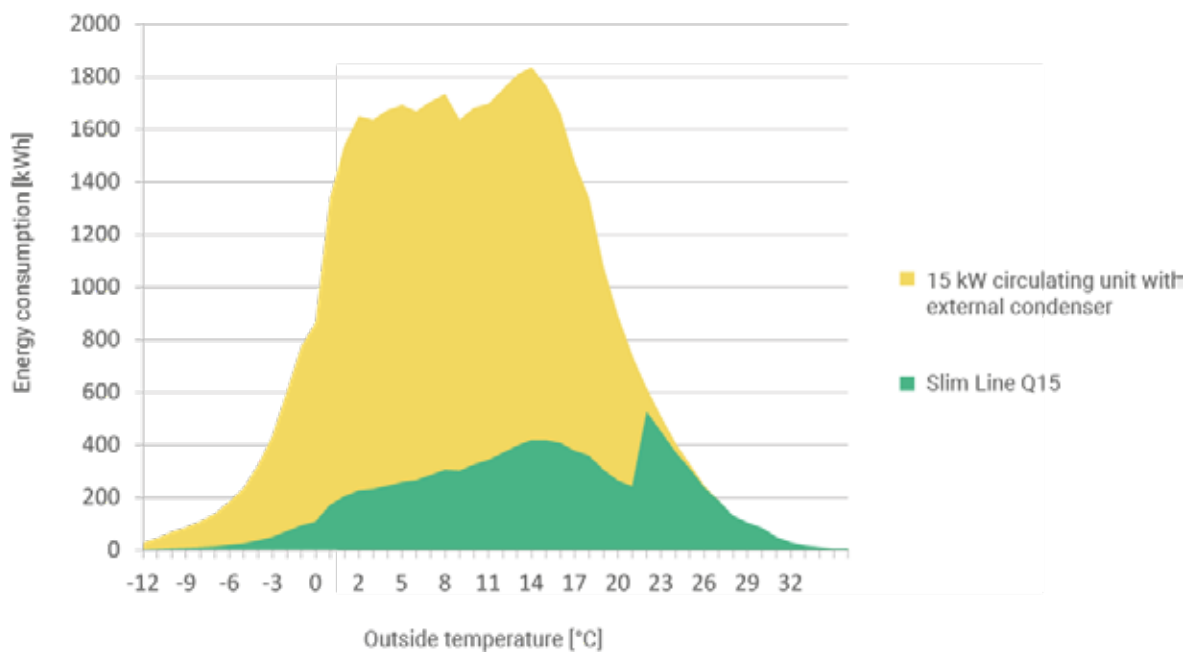

BLUE LINE IT

Tailored solutions through customisable units



HANSA Blue Line IT air handling and full air conditioning units are defined by their integrated heat recovery system and the extraordinary levels to which they can be customised. Heat recovery is either achieved through a rotor (Blue Line IT-eco-R) or our patented solution with

double cross-counterflow plate heat exchangers and adiabatic spray humidification (Blue Line IT-GS-ASB+ with patent number DE 10 2018 213 274 A1). The rotor in the Blue Line IT-eco-R can also be installed horizontally.

How Blue Line IT works

Cold outside air cools warm exhaust air emerging from the server or technical room through the heat recovery system. This is fed in the circuit again to the elements to be cooled.

Outside air that is too warm is adiabatically cooled. The supply temperature can be reduced further through a cooling coil if necessary.

This principle achieves free cooling while simultaneously separating the air

flows. Consequently, the stress on the components to be cooled caused by environmental influences is kept at a low level with maximum efficiency.

HANSA air conditioning devices help you to meet the requirements demanded by green IT. Our equipment enables you to achieve a high level of energetic efficiency, resulting in lower energy consumption and the related optimising of your data centre CO₂ footprint.



HEAT DISSIPATING UNITS

Solutions for every application

Wherever high thermal loads are generated in a process environment, these need to be dissipated as safely and efficiently as possible to ensure smooth trouble-free operation. This may involve data centres, server rooms or, in general, technical rooms such as control centres for fibre-optic networks. This objective can be achieved by cooling ambient air (air

circulation) or a regular air exchange with cool outside air (free cooling). Our HANSA units cover both approaches. With our standard Slim Line and ReCool Line units, or the highly customisable air handling and complete air conditioning Free Line and Blue Line IT units, our portfolio covers every potential and, indeed, conceivable application area.



Slim Line

Manufactured in the thousands, the highly efficient and compact units for cooling rooms under high thermal stress have an energy advantage of over 70% when compared to purely recirculation or split units.



Free Line

Our Free Line units are freely adaptable and configurable air conditioning units for free cooling of server rooms or general dissipation of process heat. They can be perfectly adapted to a range of application areas.



Recool Line

Recirculating air cooling units for cooling rooms under high thermal stress. Whatever the marginal conditions may be, place your trust in HANSA, the air conditioning specialist, and select the right recirculating air cooling unit for your needs.



3D PLANNING

Precision solutions, thanks to 3D planning

We work together with your architect or building services engineering planner right from the building design phase. Our products can be adapted to suit practically any spatial conditions.

Precision 3D planning in advance offers immense advantages, particularly where devices need to be retrofitted in an existing plant. This means that you as the

customer and us as the manufacturer are certain that everything will fit and, also, function at a later stage.

Precision 3D planning enables the achievement of finely tuned solutions that facilitate problem-free installation and perfectly address your individual requirements.



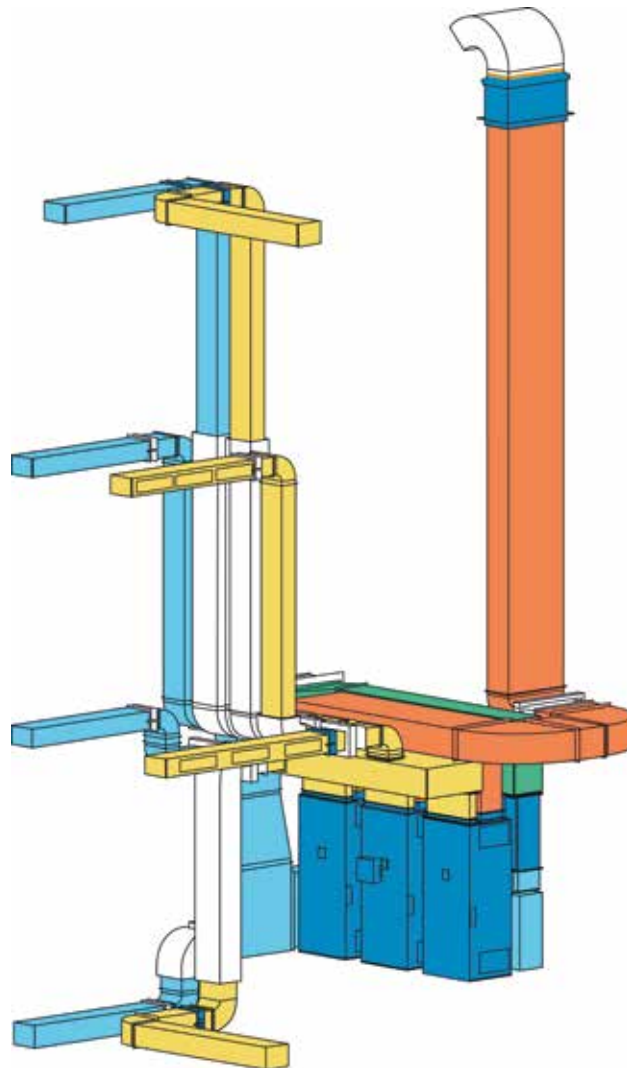

BIM

Building Information Modelling (BIM) describes a working method for the networked planning, construction and management of buildings with the aid of the latest software. Consideration of all relevant building data and extensive planning enables the optimum adaptation of HANSA units

BIM

and systems to building structures and other circumstances. The building is geometrically visualised here as a virtual model. Revit BIM models for our Slim Line and ReCool Line and compact units and Pool Line compact units are available as a download on our hansa-klima.de/en website.

REFERENCES

Deutsche Telekom AG

As one of the largest European telecommunications providers, Deutsche Telekom AG has been using air conditioning units from HANSA for over 20 years to condition air in many of its buildings.



European Central Bank (ECB)

The European Central Bank is an institution of the European Union and the common monetary authority of the Member States of the European Monetary Union. HANSA ensures that computer rooms are air conditioned.



EWE AG

EWE AG is a public utility company in the area of electricity, natural gas, telecommunications, information technology and the environment. Different EWE facilities were equipped with Slim Line Q series units.



EVO Offenbach

Energieversorgung Offenbach AG (EVO) is a utility provider supplying electricity, natural gas, water and heating. HANSA has equipped various EVO data centres with Slim Line Q series units.



Gerstenberg Verlag Hildesheim

The Gerstenberg Verlag has published books for children, adolescents and adults for seven generations. HANSA equipped its backup data centre with two Free Line units.



Kiel Fire Service control room

The central control room of the Fire Service in Kiel coordinates rescue operations in the state capital and the districts of Rendsburg-Eckernförde and Plön. The technical premises are cooled by eight Slim Line units.



Long Island University - EDP room

For the cooling of the Long Island University data centre, HANSA supplied the computer room with a Free Line unit with a maximum air capacity of 15,000 m³/h, a humidifier and direct evaporation.



Verkehrsbetriebe Karlsruhe (VBK)

Verkehrsbetriebe Karlsruhe (VBK) is the municipal transportation company in the Baden-Württemberg city of Karlsruhe. Various air conditioning units were provided for the VBK offices and computer rooms.



OUR CLIMATE

Global climate

Climate change is one of the greatest challenges we face today, which is why the reduction of emissions plays such a major role in our company. The consequences of global warming are becoming increasingly noticeable and can only be counteracted through resolute action. However, as the emission reductions currently pledged by countries are, on their own, inadequate, a consid-

erable effort is required to counter man-made climate change. We are acutely aware of our obligation to make a contribution here, as safeguarding the future of coming generations is a responsibility that we all bear. This is why we have been climate-neutral since 2020. What's more, we are the first and only company in our sector to achieve this.





Air conditioning systems

HANSA stands out through its individual air handling and air conditioning system solutions for every application area. Our focus has been on innovation and development ever since our company was founded, and we consistently strive to achieve energy and operating cost reductions in the best possible manner. WE provide optimum solutions for swimming pools, IT cooling, hygiene, industry,

laboratories, schools and much more. Air conditioning has never been easier, thanks to the best possible service and new technologies such as our in-house *etaTech* systems. The adaptability of our products and the expertise of our staff enable us to guarantee an optimum and highly efficient system solution in every case.

Working environment

The satisfaction level of each employee plays an essential role at our company. Success and sustainability can only be assured through a pleasant and fulfilling way of working. It is important to us that we design our approach here together to ensure that we develop further as a team and, consequently, as a company. We

promote the training of all our employees in order to strengthen potential. This ensures that all obstacles are removed from the career path of each individual employee. Whether as an apprentice, student, skilled worker or new employee from outside our sector, we write our success story together in our company!

FURTHER PRODUCTS

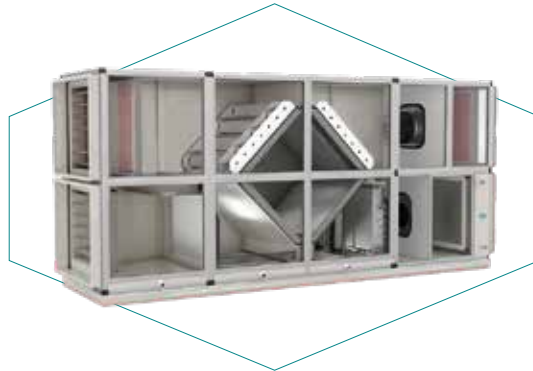

Pool Line

Swimming pool dehumidifiers provide guaranteed comfort and constant building protection. You too can benefit from the durability and energy efficiency of our units while, simultaneously, also reducing your operating costs.

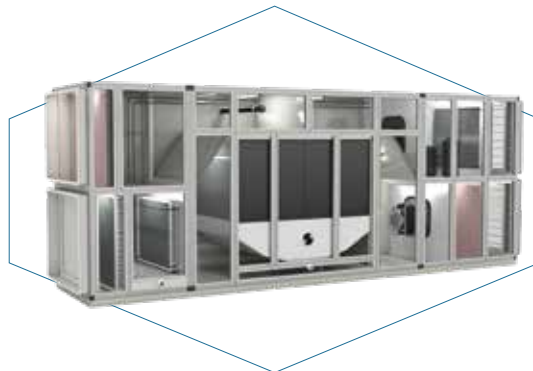

Blue Line

Highly customisable air handling and full air conditioning units with a central heat recovery system and maximum energetic efficiency. As heat recovery systems, all conventional systems can be integrated: plate exchangers, rotors, closed-loop systems and Accublock.



Compact Line

The concept behind this product line enables cost-effective manufacturing with simultaneous flexibility and application freedom, thanks to modularisation. A higher quality standard and cost-effective operation are guaranteed.



Special units

Special units encompass the LF-HY (food hygiene) and Hygro Line (recirculating air dehumidification) product series and Hepa Tower (400 and 1200) air handling units. You can obtain more precise information on all products on our website.

Our units around the world

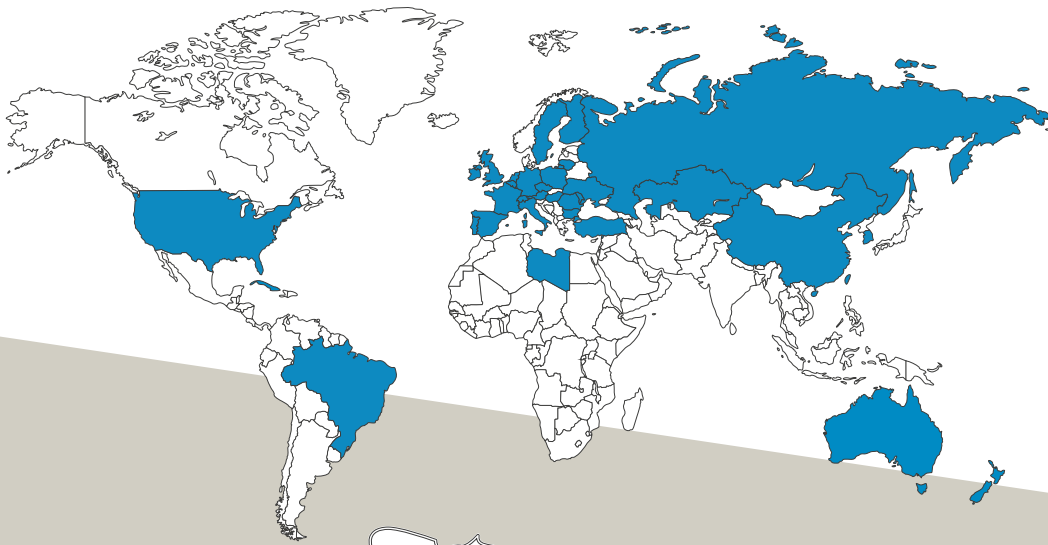

LOCATIONS





HANSA Klimasysteme GmbH

Stockweg 19
D-26683 Saterland / Strücklingen
Phone: +49 (0)4498 89-0
Fax: +49 (0)4498 687
Email address: info@hansa-klima.de

Responsibility for content:
Dr. Matthias Lamping (Dr.-Ing.)
Managing Directors:
Carsten Fenne, Jan Neumann

Tax ID No. DE 117 377 203
Registergericht Oldenburg (registry court)
HRB 151863 (German Commercial Register)



it-cooling.de/en